

# Panasonic®

## SDTI Interface Board

# Operating Instructions

---

Model No. AJ-YAG930 G

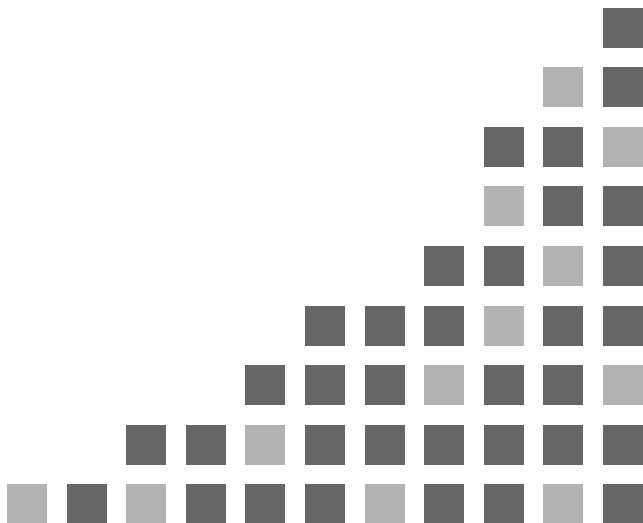

Before operating this product, please read the instructions carefully and save this manual for future use.

**CAUTION:**

TO REDUCE THE RISK OF FIRE OR SHOCK HAZARD, REFER MOUNTING OF THE OPTIONAL INTERFACE BOARD TO AUTHORIZED SERVICE PERSONNEL.

**CAUTION:**

TO REDUCE THE RISK OF FIRE OR SHOCK HAZARD AND ANNOYING INTERFERENCE, USE THE RECOMMENDED ACCESSORIES ONLY.

 indicates safety information.

## ***Precautions***

- Do not touch the product with wet hands.
  - Do not drop the product or expose it to bumps or shocks.
  - Do not attempt to modify the product.
- Doing so could cause it to malfunction.

# **Contents**

Precautions .....	2
For use with: .....	3
Features .....	3
Accessories .....	3
Installing the board .....	4
Specifications .....	9

## **For use with:**

### **Digital VTRs:**

AJ-D930, AJ-D955, AJ-SD930, AJ-SD955, AJ-SD955A

## **Features**

Installing this board in a digital VTR makes it possible to input and output digital data using the SDTI format (Serial Data Transport Interface).

<p>SDTI complies with the SMPTE 305M standard. SDTI's data stream format complies with the SMPTE 321M standard.</p>
---

## **Accessories**

- Connector board (1)
- Connecting cables (3)

## ***Installing the board***

### **CAUTION:**

These servicing instructions are for use by qualified service personnel only. To reduce the risk of fire or electric shock do not perform any servicing other than that contained in the operating instructions unless you are qualified to do so.

- 1** Disconnect the power cord from the VTR.
- 2** Remove the 2 coin screws, then remove the top panel.

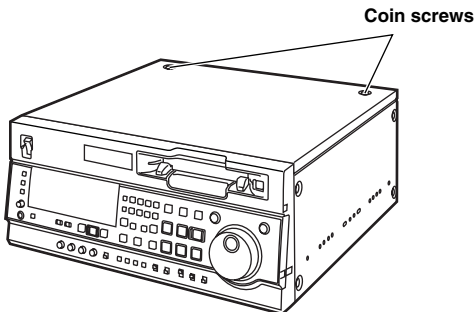

## ***Installing the board***

- 3** Loosen the screw indicated in the diagram below, then remove the board clamp.

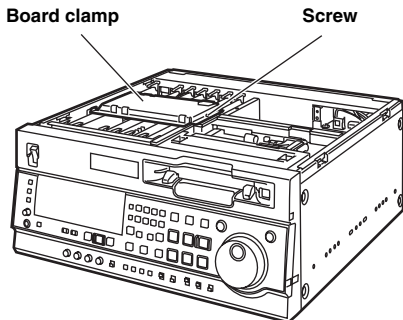

- 4** Remove the screw, then remove the blank panel from the rear panel.

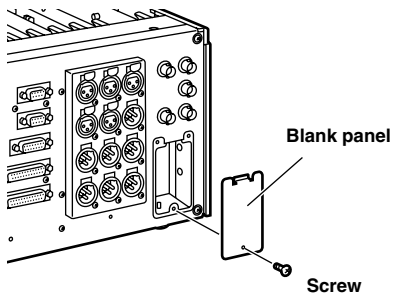

## Installing the board

- 5 Remove the SDI board from the F3 slot on the rear panel side of the VTR unit.

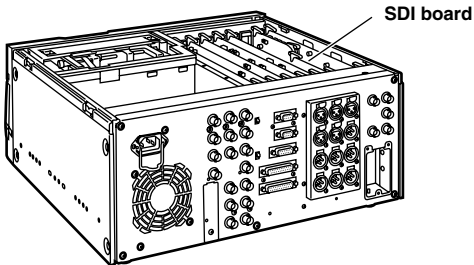

- 6 Attach the accessory connector board to the rear panel. As shown in the diagram below, after passing the SDI board's connecting cables through the hole provided for the F3 slot, plug them into the top section of the connector board and then fix the connector board in place using the screw.

**SDI board's connecting cables**

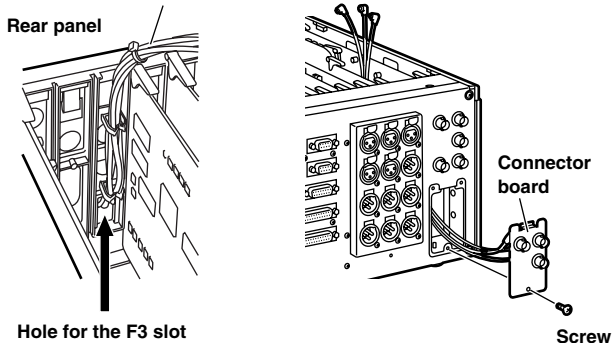

# Installing the board

7 Connect the connecting cables to the SDTI board.

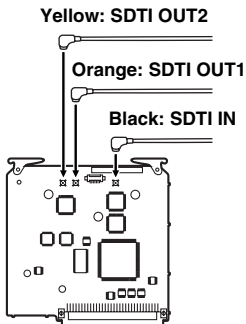

8 Reinsert the SDI board in the F3 slot, then insert the SDTI board in the same F3 slot located on the front panel side.

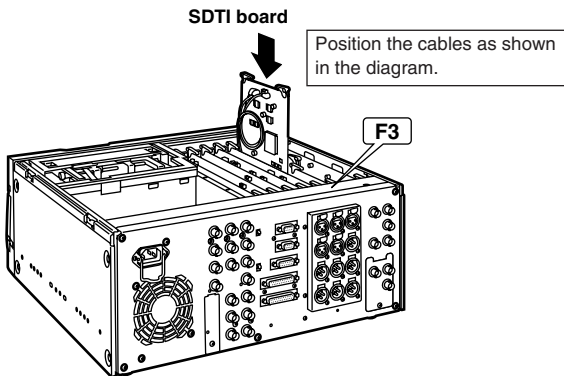

## ***Installing the board***

- 9** Reattach the board clamp using the screw, then fix the top panel in place using the 2 coin screws.

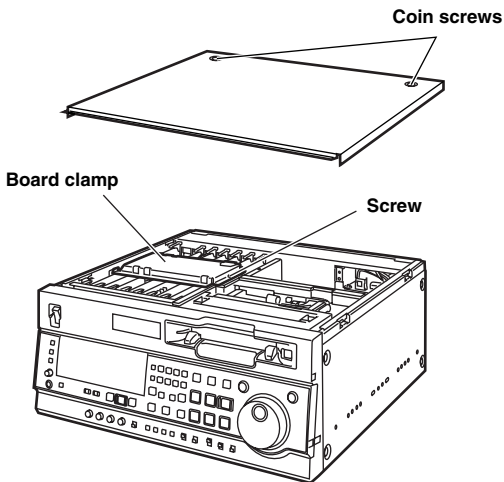

**Refer to the operating instructions of the digital VTR being used for details on the settings, operation, warning messages, etc.**



# ***Specifications***

## ■ **SDTI board**

### **Dimensions (W×H×D):**

5 11/16×5 7/8×9/16 inch (143×148×13 mm)

### **Weight:**

0.2244 lb (102 g)

## ■ **Input/Output:**

### **SDTI IN (audio/video data):**

BNC×1

(complies to the SMPTE 305M/321M standard)

### **SDTI OUT (audio/video data):**

BNC×2

(complies to the SMPTE 305M/321M standard)

# Panasonic

## PANASONIC BROADCAST & TELEVISION SYSTEMS COMPANY

UNIT COMPANY OF MATSUSHITA ELECTRIC CORPORATION OF AMERICA

### Executive Office:

One Panasonic Way 4E-7, Secaucus, NJ 07094 (201) 348-7000

### EASTERN ZONE:

One Panasonic Way 4E-7, Secaucus, NJ 07094 (201) 348-7621

#### Southeast Region:

1225 Northbrook Parkway, Ste 1-160, Suwanee, GA 30024 (770) 338-6835

#### Central Region:

1707 N Randall Road E1-C-1, Elgin, IL 60123 (847) 468-5200

### WESTERN ZONE:

3330 Cahuenga Blvd W., Los Angeles, CA 90068 (323) 436-3500

### Government Marketing Department:

52 West Gude Drive, Rockville, MD 20850 (301) 738-3840

### Broadcast PARTS INFORMATION & ORDERING:

9:00 a.m. – 5:00 p.m. (EST) (800) 334-4881/24 Hr. Fax (800) 334-4880

Emergency after hour parts orders (800) 334-4881

### TECHNICAL SUPPORT:

Emergency 24 Hour Service (800) 222-0741

### Panasonic Canada Inc.

5770 Ambler Drive, Mississauga, Ontario L4W 2T3 (905) 624-5010

### Panasonic de Mexico S.A. de C.V.

Av angel Urraza Num. 1209 Col. de Valle 03100 Mexico, D.F. (52) 1 951 2127

### Panasonic Sales Company

#### Division of Matsushita Electric of Puerto Rico Inc.

San Gabriel Industrial Park, 65th Infantry Ave., Km. 9.5, Carolina, Puerto Rico 00630  
(787) 750-4300

---

### Panasonic Broadcast Europe

Panasonic Broadcast Europe Ltd

West Forest Gate, Wellington Road, Wokingham, Berkshire RG40 2AQ U.K.

Tel: 0118 902 9200

### Panasonic Broadcast Europe GmbH

Hagenauer Str. 43, 65203 Wiesbaden-Biebrich Deutschland Tel: 49-611-1816-0

---

## 松下电器产业株式会社

Web Site: <http://www.panasonic.co.jp/global/>

---

## 松下電器産業株式会社 AVC社 システム事業グループ

☎ 57 1-8503 大阪府門真市松葉町2番15号 ☎ (06) 6901-1161